

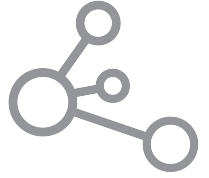

smartscape  
connected lighting systems

SMART LIGHTING • SMART SYSTEMS • SMART PEOPLE



# DDNI485

Passive Gateway

## Cost-effective optical isolation

The Philips Dynalite DDNI485 is a passive network gateway designed to provide a cost-effective optical isolation solution.

# DDNI485

## Cost-effective optical isolation

- **Electrical fault isolation** – Two opto-isolated RS-485 ports enable the DDNI485 to implement network segmentation, electrically isolating each spur and containing network faults.
- **Passive device** – Does not require programming.
- **Flexible mounting solution** – DIN-rail mountable, designed to be installed into a distribution board or other electrical enclosure.

---

## Dimensions

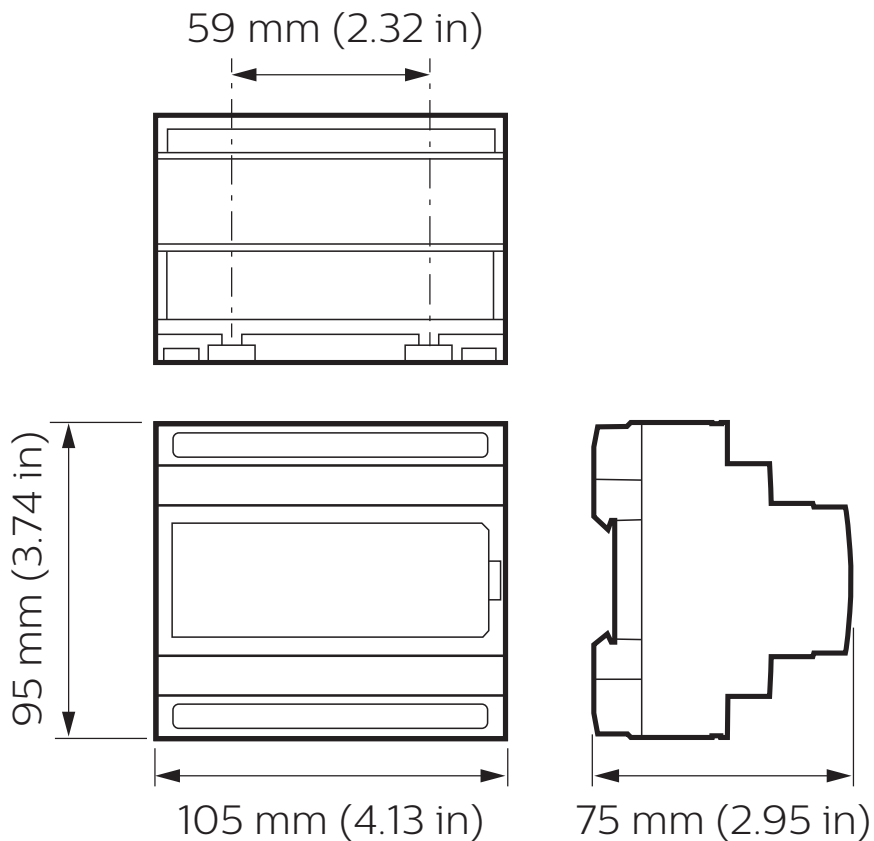

# Specifications

Due to continuous improvements and innovations, specifications may change without notice.



**DDNI485**  
Passive Gateway

## Electrical

Supply Type	DyNet (Port 1)
Supply Voltage	12 VDC
Supply Current	30 mA
Serial Port Isolation	Optical (2.75 kV surge)
IEC Overvoltage Category	III

## Control

Communication Ports	2 x RS-485
Supported Protocols	DyNet DyNet2
Indicators	2 x DyNet service LED

## Physical

Dimensions (H x W x D)	95 x 105 x 75 mm (3.74 x 4.34 x 2.95 in)
Packed Weight	0.2 kg (0.44 lb)
Construction	Polycarbonate DIN-rail enclosure (6 unit)
Communication Ports	2 x RJ12 10 x screw terminal
Communication Terminal Conductor Size	2.5 mm <sup>2</sup> (#12 AWG) (max)

## Environment\*

Operating Temperature	-0° to 50°C ambient (32° to 122°F)
Storage/Transport Temperature	-25° to 70°C ambient (-13° to 158°F)
Humidity	0 to 90% non-condensing
Ingress Protection Rating	IP20
IEC Pollution Degree	III

## Compliance

Certification	CE, RCM, UKCA, RoHS
---------------	---------------------

\* For indoor installation only



Electrical

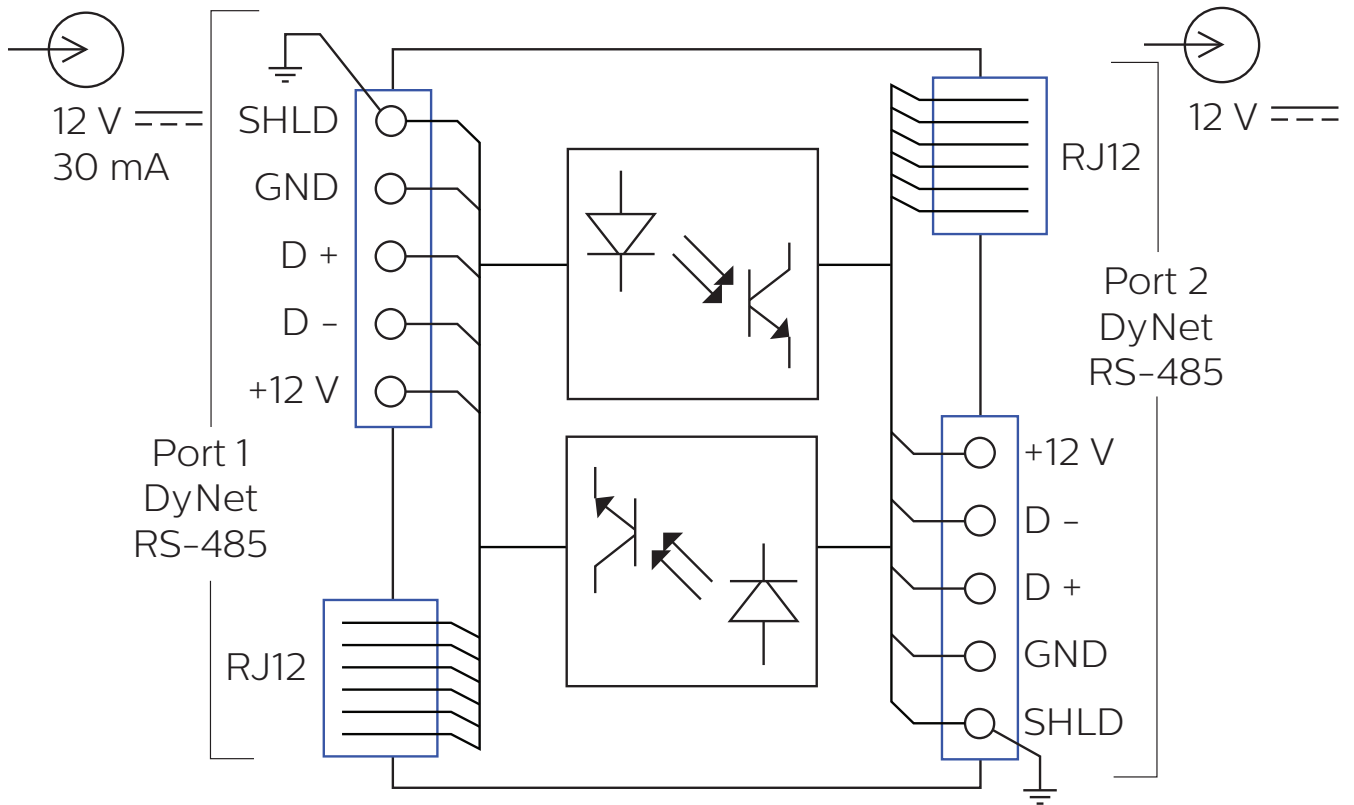

Ordering Code

**Product**

**Philips 12NC**

DDNI485

913703081309



© 2021 Signify Holding. All rights reserved. Specifications are subject to change without notice. No representation or warranty as to the accuracy or completeness of the information included herein is given and any liability for any action in reliance thereon is disclaimed. Philips and the Philips Shield Emblem are registered trademarks of Koninklijke Philips N.V. All other trademarks are owned by Signify Holding or their respective owners.

Revision 04 2021-09-09