

DUS360CR-D

Multifunction Sensor

Low-profile recessed 360° ceiling sensor powered by the DALI network

The Philips Dynalite DUS360CR-D is a recess mountable 360 degree multifunction sensor that combines motion detection (PIR) and ambient light level detection (PE) in one device. The DUS360CR-D is powered and communicates to the networked control system via a DALI bus.

DUS360CR-D

Low profile recessed 360° ceiling sensor powered by the DALI network

- **DALI device** – Designed to operate seamlessly with the Philips Dynalite DDBC120-DALI or DDBC320-DALI controller.
- **Powered directly by the DALI network** – Eliminates the need for additional network field wiring.
- **Motion detection feature** – Detection of motion within a scanned area triggers a programmed lighting action.
- **Segmented click-up bezel** – Surrounds the motion sensor element and enables a portion of the sensing field to be masked. This prevents nuisance detection from adjacent doorways or corridors.
- **Daylight harvesting mode** – Delivers automatic energy savings.
- **Ambient light level regulation** – In applications where it is critical to maintain precise light, the PE function reads ambient levels and adjusts artificial light levels accordingly.
- **Infrared receive capability** – Enables sign-on identification to the networked system.
- **Corridor hold** – Links corridor areas with adjacent rooms so corridor remains lit while occupancy is detected in adjacent rooms.

Dimensions

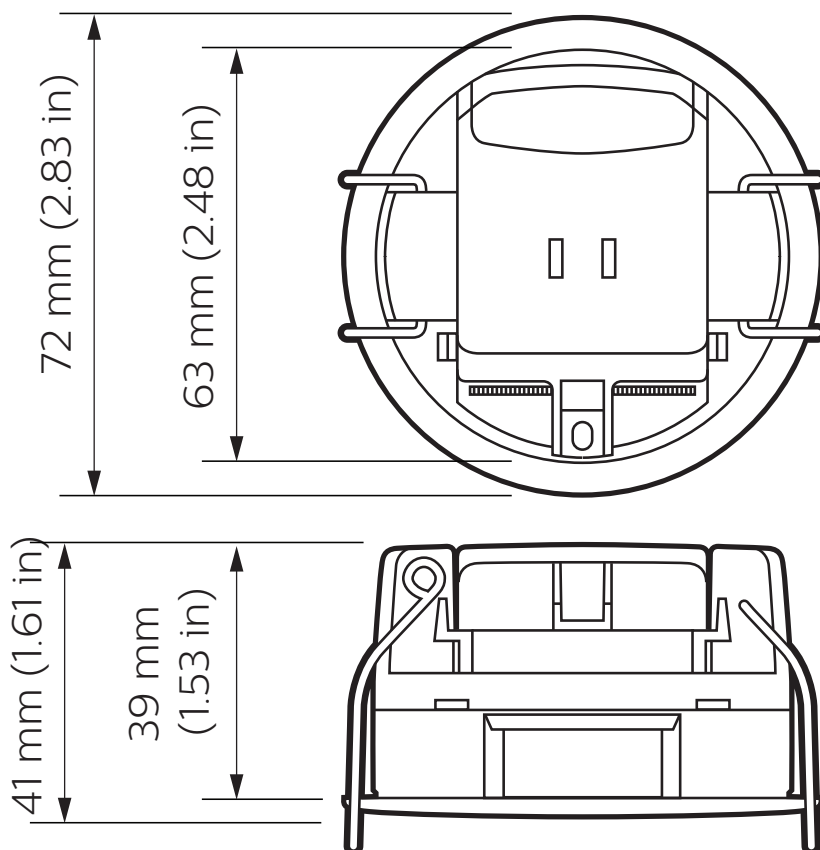

Specifications

Due to continuous improvements and innovations, specifications may change without notice.



DUS360CR-D
Multifunction Sensor

Electrical

Supply Type	DALI / ELV
Supply Voltage	9.5-22.5 VDC
Supply Current	9 mA (up to 10 user interfaces on one DALI universe)
DALI Insulation	Basic
IEC Overvoltage Category	III

Motion Detection (PIR)

Sensor	Quad element pyroelectric
Maximum Detection Range	5 m (16.4 ft)*
Detection Area	See next page

Light Detection (PE)

Lux Range	5-5000 lux
-----------	------------

Control

Serial Ports	1 x DALI
User Input	Infrared (RC5 IR remote control) 1 x service switch
Indicators	1 x red motion LED

* Typical detection range at $\leq 25^{\circ}\text{C}$ (77°F). Range is reduced at higher temperatures.

Physical

Dimensions (H x W)	41 x 72 mm (1.61 x 2.83 in)
Packed Weight	0.105 kg (0.23 lb)
Construction	Polycarbonate plastic enclosure
Color	RAL9010 (White) RAL9005 (Black)
Serial Ports	1 x 2-way screw terminal
Screw Terminal Conductor Size	2.5 mm ² (#12 AWG) (max)
Mounting Substrate Thickness	3-25 mm (0.12-0.98 in)

Environment**

Operating Temperature	0° to 45°C ambient (32° to 113°F)
Storage/Transport Temperature	-25° to 70°C ambient (-13° to 158°F)
Humidity	0 to 90% non-condensing
IEC Pollution Degree	II

Compliance

Certification	CE, RCM, UKCA, RoHS
IP Rating	IP20

** For Indoor Installation Only

Detection Area

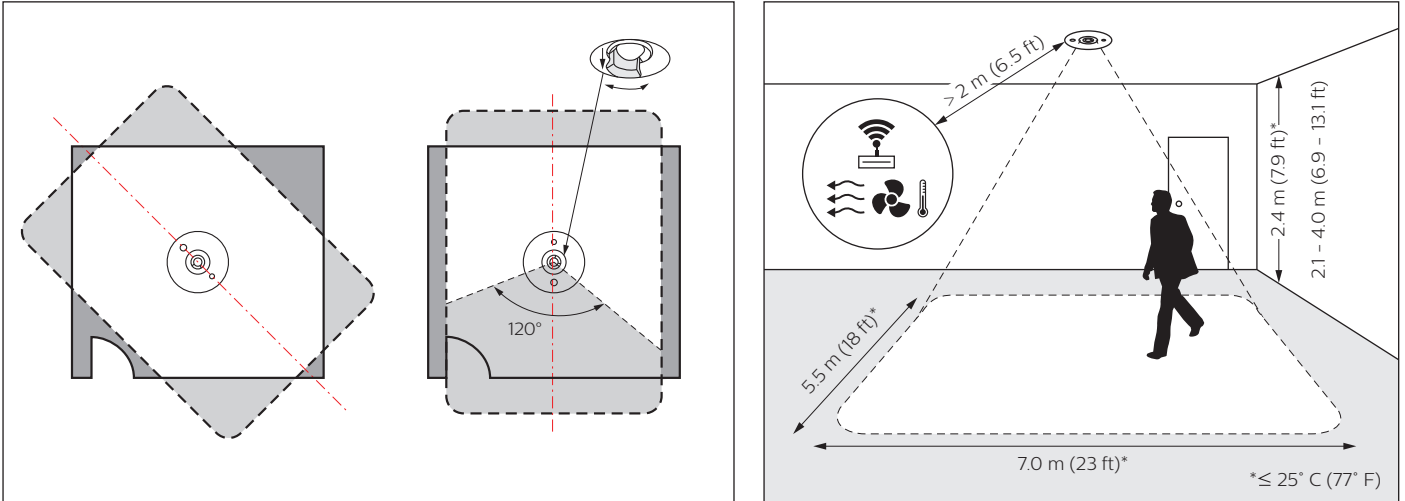

Ordering Code

Product	Philips 12NC
DUS360CR-D	913703213009
DUS360CR-D-RAL9005 (Black)	913703338409
Accessories	Philips 12NC
IRT9090/01 (commissioning & testing RC5 IR remote control)	913700359103
IRT9010/00 (user-friendly RC5 IR remote control)	913700392403



© 2022 Signify Holding. All rights reserved. Specifications are subject to change without notice. No representation or warranty as to the accuracy or completeness of the information included herein is given and any liability for any action in reliance thereon is disclaimed. Philips and the Philips Shield Emblem are registered trademarks of Koninklijke Philips N.V. All other trademarks are owned by Signify Holding or their respective owners.

Revision 15 2022-09-29