

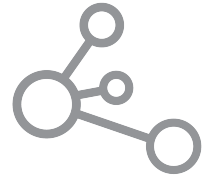

smartscape
connected lighting systems

SMART LIGHTING • SMART SYSTEMS • SMART PEOPLE



DUS90AHB-D

Multifunction Sensor

Aisleway high bay DALI network sensor

The Philips Dynalite DUS90AHB-D is a 90 degree multifunction sensor that combines motion detection (PIR) and ambient light level detection (PE) in one device. The sensor uses the DALI protocol for power and communications to a network control system, eliminating the need for additional network field wiring. This sensor is ideal for mounting between warehouse shelving.

DUS90AHB-D

Aisleway high bay DALI network sensor

- **DALI device** – Designed to operate seamlessly with the Philips Dynalite DDBC120-DALI or DDBC320-DALI controller.
- **Powered directly by the DALI network** – Eliminates the need for additional network field wiring.
- **Motion detection feature** – Detects the presence or absence of motion and triggers a programmed action.
- **Ambient light level detection** – In applications where it is critical to maintain precise lighting levels, the PE function reads ambient levels and adjusts artificial light accordingly.
- **Daylight harvesting** – When used in conjunction with networked open loop daylight sensor.
- **Infrared receive capability** – Enables sign-in identification to the networked system.
- **Corridor hold** – Links corridor areas with adjacent rooms so corridor remains lit while occupancy is detected in adjacent rooms.
- **Targeted positioning** – Directional wallmounting block allows sensors to be easily mounted and directed to the required area.

Dimensions

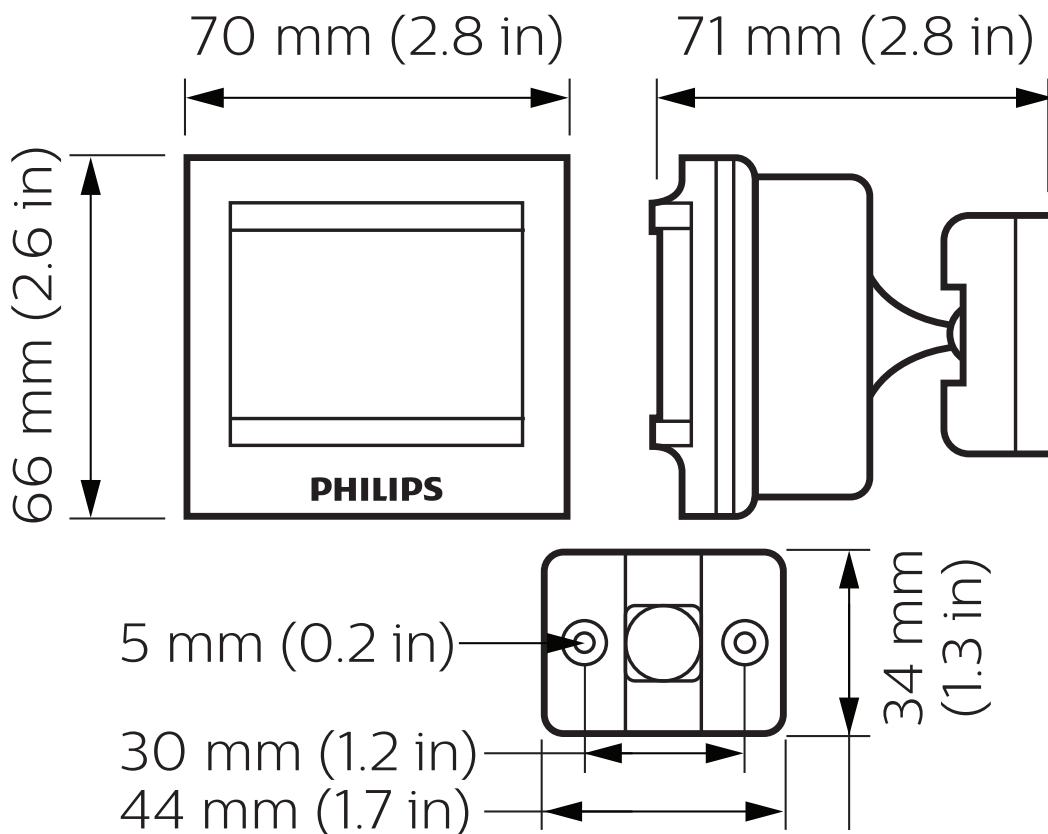

Specifications

Due to continuous improvements and innovations, specifications may change without notice.



DUS90AHB-D
Multifunction Sensor

Electrical

Supply Type	DALI / ELV
Supply Voltage	9.5-22.5 VDC
Supply Current	9 mA (up to 10 user interfaces on one DALI universe)
DALI Insulation	Basic
IEC Overvoltage Category	III

Motion Detection (PIR)

Sensor	Dual element pyroelectric
Maximum Detection Range	15 m (49 ft)*
Scan Beam Angle	90°
Detection Area	See next page

Light Detection (PE)

Lux Range	5-10,000 lux
-----------	--------------

Control

Serial Ports	1 x DALI
User Input	Infrared (RC5 IR remote control) 1 x service switch
Indicators	1 x red motion LED

* Typical detection range at $\leq 25^{\circ}\text{C}$ (77°F). Range is reduced at higher temperatures.

** Fly lead included.

Physical

Dimensions (H x W x D)	66 x 70 x 71 mm (2.60 x 2.76 x 2.80 in)
Packed Weight	0.116 kg (0.26 lb)
Construction	Polycarbonate plastic enclosure
Color	White (RAL9010)
Serial Ports	1 x 2-way screw terminal
Screw Terminal Conductor Size**	0.75 mm ² (#18 AWG) (max)

Environment

Operating Temperature	-5° to 50°C ambient (23° to 122°F)
Storage/Transport Temperature	-25° to 70°C ambient (-13° to 158°F)
Humidity	0 to 90% non-condensing
IEC Pollution Degree	II

Compliance

Certification	CE, RCM, UKCA, RoHS
IP Rating	IP40 (When installed as per manufacturer instructions)

Detection Area

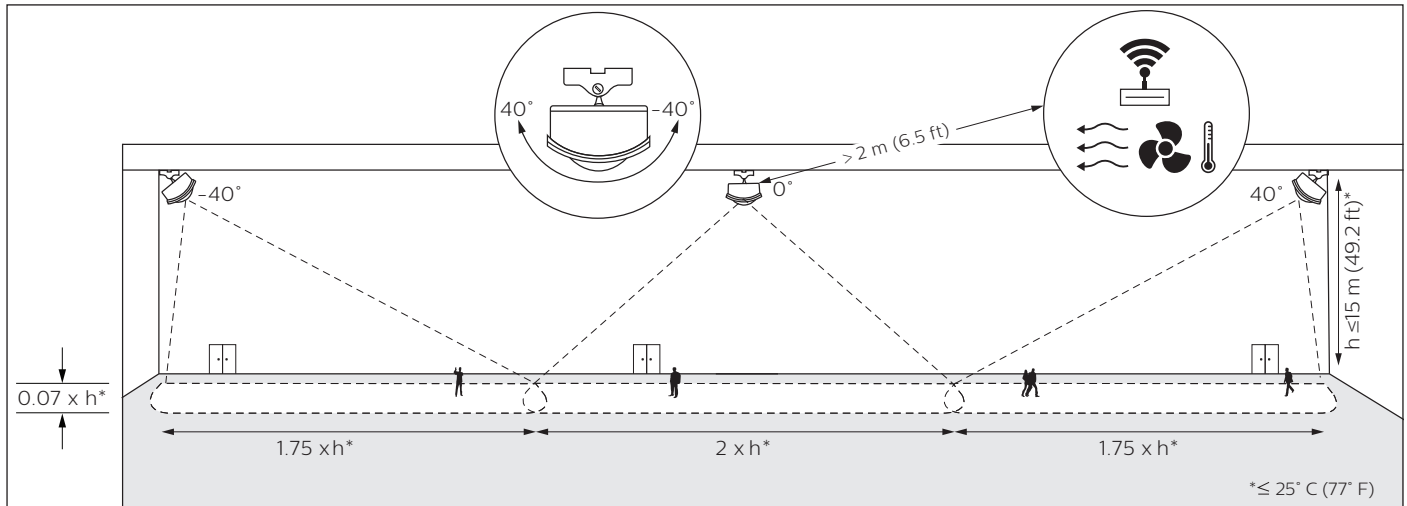

Ordering Code

Product	Philips 12NC
DUS90AHB-D	913703015409
Accessories	Philips 12NC
IRT9090/01 (commissioning & testing RC5 IR remote control)	913700359103
IRT9010/00 (user-friendly RC5 IR remote control)	913700392403



© 2022 Signify Holding. All rights reserved. Specifications are subject to change without notice. No representation or warranty as to the accuracy or completeness of the information included herein is given and any liability for any action in reliance thereon is disclaimed. Philips and the Philips Shield Emblem are registered trademarks of Koninklijke Philips N.V. All other trademarks are owned by Signify Holding or their respective owners.

Revision 07 2021-09-10