

smartscape

connected lighting systems

SMART LIGHTING • SMART SYSTEMS • SMART PEOPLE

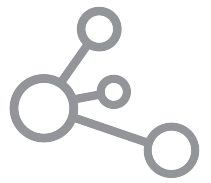

PHILIPS

dynalite

User Interfaces



PDTS

Networked Touchscreen

Advanced building automation and control at your fingertips

Designed as an integral part of the Dynalite system, the PDTS offers intelligent control and direct access to scheduling, scene editing, diagnostics, and local environmental sensing.

Combining Ethernet connectivity, a powerful onboard processor, and contemporary design cues from the Antumbra user interface range, the PDTS is a sleek, functional complement to any project.

PDTS

Advanced building automation and control at your fingertips

- **178 mm capacitive touchscreen** – With high resolution, rich color and wide viewing angle.
- **Proximity sensor** – Triggers soft halo light effect to welcome user interaction.
- **Ethernet port** – Provides access for commissioning and file transfers.
- **Internal astronomical timeclock** – Enables advanced scheduling of behavior, options, and automated tasks based on time of day or sunrise/sunset.
- **Customizable graphical menus** – Seamless control of lighting, curtains/blinds, HVAC, A/V equipment and compatible third-party systems.
- **Built-in environmental sensors** – Humidity and temperature can be displayed on standby screen and communicated to third-party systems.
- **Templated commissioning option** – Simply load the project XML file for fast configuration, or upload custom web pages from System Builder.
- **Thin profile and easy mounting** – Fits industry-standard double wall boxes (EU or US).
- **Secure access** – Employs HTTPS for secure, encrypted network communication, with support for onboard security certificates.
- **User authentication** – Secure login feature available for CGI commands and user functions, with customizable access levels for each user.

Dimensions

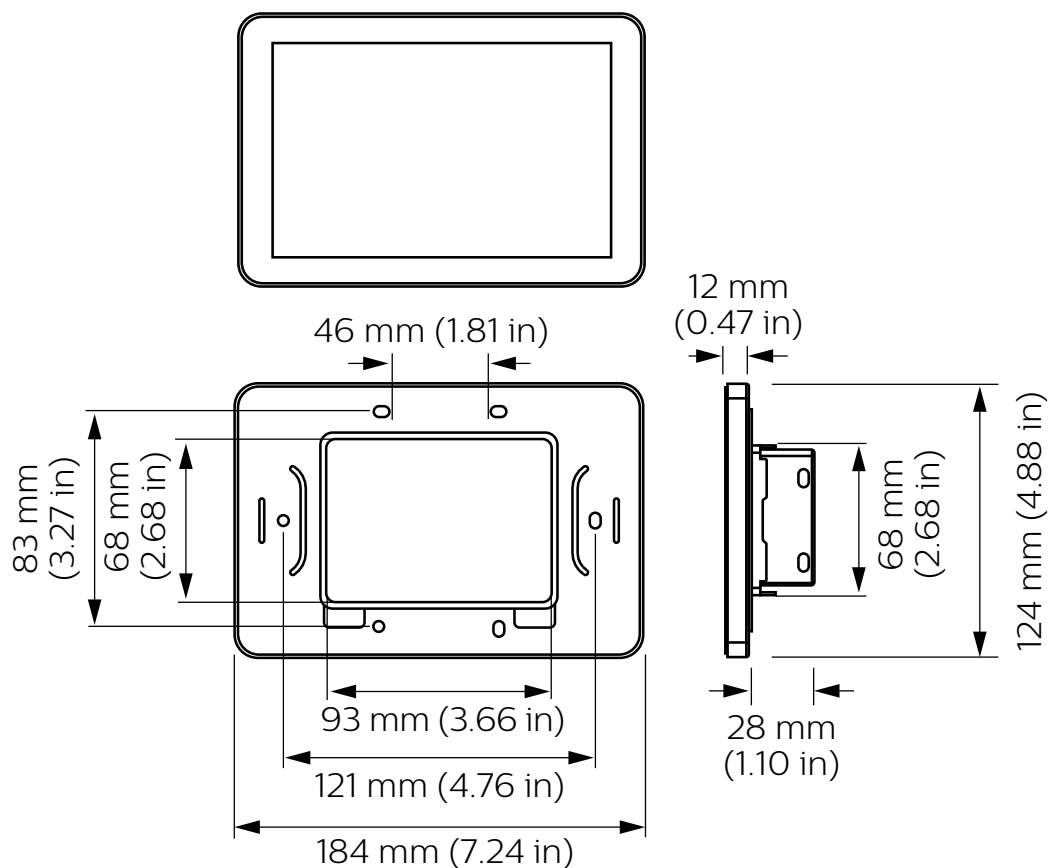

Specifications

Due to continuous improvements and innovations, specifications may change without notice.



PDS
Networked Touchscreen

Electrical

Supply Type	SELV / CLASS 2 (UL) external, regulated DC (Sold separately, see Accessories below)
Supply Voltage	12-24 VDC
Supply Current	500 mA @ 12 VDC 300 mA @ 24 VDC
IEC Overvoltage Category	III

Display

Screen Type	LCD capacitive touchscreen
Viewable Area	94 x 150 mm (3.70 x 5.91 in) Diagonal 178 mm (7.01 in)
Resolution	1280 x 800
Color Depth	16 million colors
Viewing angle	80°

Communication

Ports	1 x RS-485 1 x Ethernet (100 BaseT)
Supported Protocols	DyNet TCP/IP (TCP, UDP, IPv4/IPv6) HTTPS / CGI
Clock Features	365 day clock Lithium backup battery Sunrise/sunset tracking Automatic daylight saving adjustment
Storage Capacity	16 MB file storage (max) (28-day rolling network log) 250 timed events 64 tasks
User Inputs	1 x service/reset switch
Indicators	Power Cycle LED (blue) Boot/Recovery Mode LED (red)
Audio	1 x Speaker

Physical

Dimensions (H x W x D)	124 x 184 x 40 mm (7.24 x 4.88 x 1.57 in)
Mounted Thickness	11 mm (0.43 in)
Packed Weight	0.7 kg (1.54 lb)
Fascia Finish	Glass
Serial Ports	1 x RJ45 (Ethernet) 1 x 5-way pluggable screw terminal +V, D-, D+, GND, SHLD
Serial Port Conductor Size	2.5 mm ² (#12 AWG) (max)
Supply Terminals	1 x 2-way pluggable screw terminal +, -
Supply Terminal Conductor Size	2.5 mm ² (#12 AWG) (max)
Orientation	Landscape only

Environment*

Operating Temperature	0° to 45°C ambient (32° to 113°F)
Storage/Transport Temperature	-25° to 55°C ambient (-13° to 140°F)
Relative Humidity	0 to 90% non-condensing
IP Rating	IP40
IEC Pollution Degree	II

Compliance

Certification	CE, RCM, UL, FCC, ICES, UKCA, RoHS
---------------	------------------------------------

* For indoor installation only



Ordering Codes

Product	Philips 12NC
PDS	913703334309

Accessories

DDNP1501	(12 VDC network power supply)	913703090309
DMNP24040-P-NA	(24 VDC network power supply)	913703580309



© 2022 Signify Holding. All rights reserved. Specifications are subject to change without notice. No representation or warranty as to the accuracy or completeness of the information included herein is given and any liability for any action in reliance thereon is disclaimed. Philips and the Philips Shield Emblem are registered trademarks of Koninklijke Philips N.V. All other trademarks are owned by Signify Holding or their respective owners.

Revision 14 2021-09-10